

VINE REMOVER

Separate Vines From Product
Flow In Receiving



The Vine Remover uses a bed of rolls to separate and remove vines from your in-plant product flow. Integrate with our Hydrolift Destoner vertical augers, Flume Systems, and more in your receiving process to get the most debris-free product possible and continuous processing without stoppages. We collaborate with you to determine the best layout and configuration – from inline to offline, tandem or multiple machines, and more. After separating vines, takeaway solutions include conveying or cart.

The Vine Remover is an essential machine to thoroughly prep your potatoes from crop to processing.

- Single machine flow rates up to 130,000 pounds (65 tons) per hour
- Custom urethane molded, hex tube, and grit rolls are configured to your product and application
- Flexible operation inline or offline, with tandem or multiple machines, and at a range of pitches
- Integrate with Hydrolift Destoner vertical augers, Flume Systems, and more to complement your receiving process
- Maintenance-friendly sanitary design with easy access panels and cover, and simple roll operation and changeouts

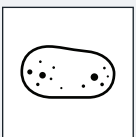

Potatoes

Vine Remover

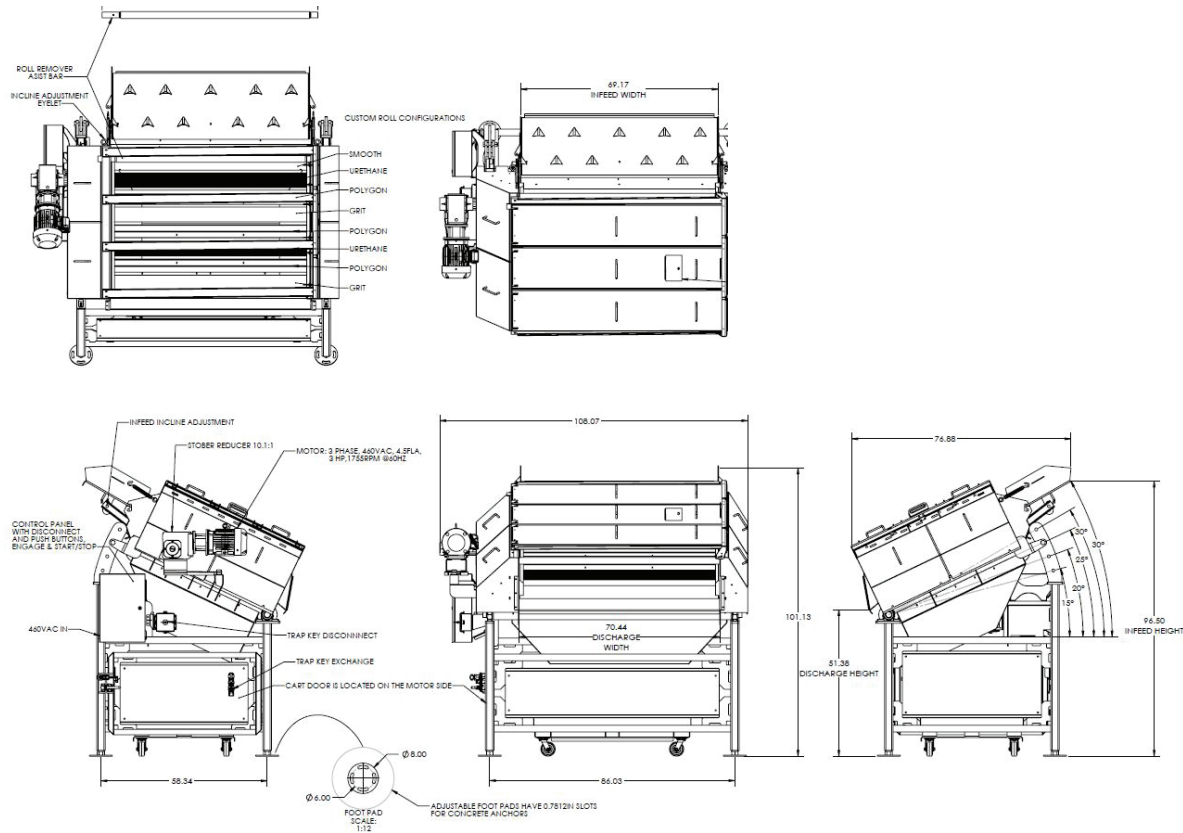

Specifications

Dimensions (overall):
108x103x74" (274x261x188 cm)

Hourly Flow Rate:
up to 130,000 lbs. (65 tons)

Pitch Angles:
Infeed – 20-40 degrees;
Roll Chamber – 15-30 degrees

Electrical: 3 Phase, 460V

Motor: 1755RPM @60HZ

Features

- Single 10:1 reducer
- VFD controlled
- Control panel and local e-stop disconnect
- 24V trap key
- Custom urethane molded, hex tube, and grit rolls
- 304 stainless steel construction

Options

- Tandem model
- Platform
- Takeaway conveyor or carts
- Flume Systems
- Hydrolift Destoner

E 1.23v6

Contact Us

Vanmark is proud to provide top quality equipment, exceptional service and peace of mind worldwide for the potato and produce processing industries. Contact us for more information and to custom-fit the Vine Remover for your specific application.



To feed our growing world - Together

Phone: +1 740-201-0004

Email: sales@vanmark.com

vanmark.com